

<b>883★</b>	<b>884★</b>	<b>804★</b>
05.8	05.8	05.8

品名 寸法	日栄	アカギ		VP用	VP用	PC用	PC用	PC用	ハード	ハード	ハード
	らく吊	吊バンド タン付	立バンド	吊バンド タン付	立バンド	吊バンド	吊バンド タン付	立バンド	吊バンド	吊バンド タン付	立バンド
10 3/8				200	130						
15 1/2	170	170	100	200	130	180	250	190	120	250	170
20 3/4	180	180	110	210	140	190	260	200	130	260	170
25 1	180	180	120	210	140	200	280	210	140	280	180
32 1 1/4	190	190	130	230	150	270	350	290	160	290	190
40 1 1/2	210	210	140	250	160	290	360	300	170	300	210
50 2	220	220	160	250	170	300	380	330	190	330	240
65 2 1/2	260	260	190	370	250	370	450	390	270	410	310
80 3	280	280	230	380	280	410	490	430	290	430	330
100 4	310	310	240	510	320	450	530	470	320	450	360
125 5	920	920	710	1,110	1,000				1,380	1,750	1,470
150 6	1,030	1,030	840	1,220	1,320				1,450	1,830	1,560
200 8	1,920	1,920	1,710	2,000	1,880				5,800	7,020	
250 10	5,620	5,620	3,660								
300 12	8,370	8,370	6,420								
350 14	10,560	10,560									

(単位：円 / 個)

<b>804★</b>
改定2008.8

品名 寸法	U ボ ル ト					足長+50	PC用	角型	タン付	置き	置きローラー
	1/4	5/16	3/8	1/2	5/8	Uボルト	Uボルト	吊ローラー	吊ローラー	ローラー	ガイド付
10 3/8	50										
15 1/2	50	60	100			290	180	660	550	620	760
20 3/4	60	60	110			310	190	660	550	620	760
25 1	60	60	120			330	200	700	590	640	950
32 1 1/4	60	70	120			350	220	740	810	670	1,010
40 1 1/2	70		100			380	250	820	810	750	1,140
50 2	80		110			410	270	900	900	810	1,230
65 2 1/2	150		130			430	320	1,220	1,180	1,040	1,530
80 3	160		130	410		450	360	1,590	1,500	1,330	1,940
100 4	170		150	470		520	380	1,980	1,850	1,650	2,740
125 5			450	420		1,070		2,640	2,510	2,140	3,450
150 6			470	460		1,190		3,540	3,080	2,260	3,990
200 8				580		1,560		5,850	8,780	3,980	6,460
250 10					1,390			6,490		4,360	
300 12					1,960						
350 14					2,360						

(単位：円 / 個)

804★

## 配管用支持金具

改定2008.8

【新定価 2008年8月～】



品名 寸法	サドル バンド	厚口 サドル バンド	床 バンド	ハード 床 バンド	デップ 銅管用 吊タン付	デップ 銅管用 立バンド	デップ 銅管用 Uボルト	デップ サドル バンド	銅管用 床バンド ゴム付	デップ SU用 吊タン付	デップ SU用 立バンド	デップ SU用 Uボルト
8					400	360						
10					370	320	250	280				
13	20									380	320	400
15	20	80	390	390	380	320	270	290	760			
16					410	360						
20	30	90	410	410	420	360	290	300	850	410	360	430
25	30	100	420	420	430	390	320	330	910	430	390	450
30										450	440	550
32	40	130	440	440	450	440	380		990			
40	50	150	450	450	500	530	400		1,060	500	530	620
50	60	170	480	480	530	550	430		1,150	530	550	680
60									下記デップ銅管用床バンド↓	660	690	730
65	210	210	670	670	660	690	500		4,370			
75										730	760	820
80	240	240	690	690	730	760	520		4,970	850	890	900
100	260	260	780	780	850	890	540		5,830	880	960	990
125		750	1,500	1,500								
150		1,100	2,010	2,430								
200		1,910	3,260									

品名 寸法	ステンレス スパイラル 吊タン付	鉄 スパイラル 吊タン付	デップ スパイラル 吊タン付
80	460		
100	480	840	1,060
125	530	900	1,120
150	630	960	1,240
175	930	1,440	
200	780	1,470	1,430
225	900	1,570	
250	1,000	1,780	1,950
275		1,930	
300	1,690	2,080	
350	2,080	2,380	

品名 寸法	T足	座付 羽子板	ターボ 羽子板	溶接 T足 32幅	溶接 羽子板 32幅	ツバ付 足 25幅	ツバ付 足 32幅
30	100	180				(化粧ネジ足)	(化粧ネジ足)
40	110						
50	110	180	230			300	
60	110				650	310	330
65	110	190	240				
75	130	200	250				
80	150			730	690	330	340
100	150	210	280	810	740	350	380
125	170	220	300	850	770	370	410
150	210	260	320	940	800	400	440
200	280	410	430			870	900

品名 寸法	シーリング プレート	ビニール プレート	ホース ニップル 白
15	150	180	750
20	160	190	830
25	190	230	1,050
32	230	270	1,260
40	280	310	1,370
50	310	390	2,160
65	440	490	3,870
80	500	650	5,050
100	700	720	8,020
125	1,200	1,250	
150	1,450	1,560	

品名	50~100 寸法	溶接 T足	105~155 寸法	溶接 T足	160~300 寸法	溶接 T足
溶接 T足	50L	280	105L	390	160L	530
	55L	300	110L	390	165L	530
	60L	300	115L	390	170L	530
	65L	310	120L	390	175L	530
	70L	320	125L	430	180L	530
	75L	320	130L	430	185L	530
	80L	320	135L	430	190L	530
	85L	360	140L	430	200L	530
	90L	360	145L	470	~250L	1,200
	95L	360	150L	470	~270L	1,240
100L	360	155L	530	~300L	1,290	



ターボ羽子板

その  
関連  
製品  
他

(単位：円/個)

<b>885★</b>
改定2008.8

<b>804★</b>
改定2008.8

<b>886★</b>
改定2008.8

品名 寸法	フネン用					鋳鉄管用		
	吊バンド タン付	立バンド	床バンド	Uバンド	サドル バンド	吊バンド	立バンド	床バンド
40	370	350	660	870	400			
50	380	380	700	920	420	440	380	
65	410	410	760	950	450	500	450	
75	460	440	810	1,000	470	500	440	950
100	500	540	1,060	1,040	500	560	510	1,080
125	1,100	1,140	1,880	1,220		1,380	1,500	1,740
150	1,320	1,290	2,390	1,440		1,560	1,760	2,440

品名 寸法	メッキホッパー	
	内ネジ	外ネジ
32A×80 φ	6,000	6,480
32A×100 φ	6,000	6,600
32A×125 φ	6,960	6,960
32A×150 φ	7,730	7,730
40A×80 φ	6,580	6,580
40A×100 φ	6,600	6,600
40A×125 φ	7,440	7,440
40A×150 φ	7,970	8,180
50A×100 φ	7,100	7,100
50A×125 φ	7,780	7,780
50A×150 φ	8,210	9,090
50A×200 φ	18,000	18,600
65A×100 φ	9,600	9,600
65A×125 φ	10,800	11,400
65A×150 φ	11,400	12,960
65A×200 φ	20,640	20,640
80A×125 φ	13,680	13,680
80A×150 φ	15,550	15,550
80A×200 φ	21,940	21,940
100A×150 φ	17,730	16,850
100A×200 φ	23,230	23,230
125A×200 φ	29,810	29,810

<b>804★</b>
改定2008.8

品名 寸法	防振(3t) ハード 吊タン付	防振(3t) ハード 立バンド	PC用 防振 ハード 吊タン付	PC用 防振 ハード 立バンド	防振 吊タン付 (10t)	防振 Uバンド (10t)	PHハード 吊タン付 (ブラック)	PHハード 立バンド (ブラック)	PH防振 吊タン付 (10t)
15	440	460	590	640	1,010	970	810	550	1,590
20	460	480	700	670	1,030	1,040	850	590	1,630
25	480	500	725	840	1,040	1,070	890	640	1,840
32	590	650	840	1,050	1,150	1,090	1,010	750	2,310
40	660	720	960	1,080	1,200	1,140	1,080	800	2,420
50	710	740	1,020	1,130	1,240	1,200	1,100	840	2,490
65	760	830	1,210	1,330	1,340	1,300	1,290	1,020	2,740
80	860	910	1,310	1,430	1,470	1,400	1,650	1,390	2,960
100	1,030	1,090	1,340	1,450	1,590	1,500	1,690	1,460	3,020
125					3,150	2,100	3,430	3,090	5,360
150					3,500	2,600	3,940	3,430	6,130

<b>887★</b>
改定2008.8

GP用 レベルバンド									
寸法	15~32	40	50	65	80	100	125	150	フリーサイズ
120H	790	810	850	910	940	1,210			860
150H	840	860	910	970	1,000	1,250	5,060	5,370	910
180H							5,060	5,370	
200H	1,240	1,560	1,620	1,690	1,750	2,440			

  

フネン用 レベルバンド							
寸法	40	50	65	80	100	125	150
120H	1,020	1,080	1,130	1,230	1,530		
150H	1,070	1,130	1,180	1,290	1,590	5,240	5,680
200H	1,330	1,400	1,470	1,600	1,990		

<b>804★</b>
改定2008.8

寸法	角サドル	
	鉄	ステンレス
60	350	1,650
65	380	1,820
70	400	1,980
75	430	2,140
80	480	2,300
90	550	2,460
100	650	3,260

(単位：円 / 個)

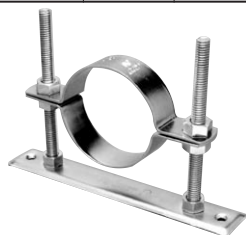

レベルバンド (GP・VP)



立バンド / SGP



防振吊 1型

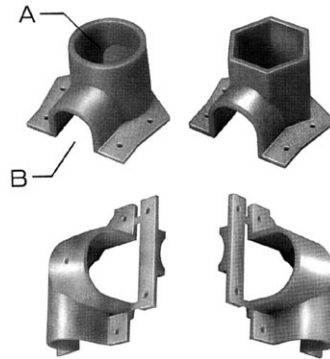

エルボブラケット

品名	鉄タンバックル
寸法	
3/8×25	80
1/2×32	240
5/8×50	1,220
品名	鉄ストロングタンバックル
寸法	
3/8×25	140
3/8×32	240
1/2×25	330
1/2×32	300
1/2×38	450
1/2×50	530
5/8×50	1,220

品名	水栓プレート (ツバ付)							
寸法	3mm	5mm	8mm	10mm	13mm	16mm	20mm	25mm
1/2	130	140	150	170	190	210	240	260
3/4	130	140	150	170	190	210	240	260

品名	エルボブラケット					
	鉄製	樹脂製				
寸法	1/2	1/2	1/2右	1/2左	1/2穴	1/2×3/4
価格	250	300	300	300	300	330

品名	ロットソケット
寸法	
3/8×40	120
1/2×40	150

品名	三連鎖付タンバックル	
寸法		
3/8	1,200	
1/2	1,480	
品名	固定タンバックル 内ネジ	
寸法		
3/8	250	
品名	固定タンバックル 外ネジ	
寸法		
1/2	200	

品名	防振吊 1型	防振吊 W型
寸法		
AD-340	2,070	3,840
AD-350	2,360	4,370
AD-360	2,910	5,590
AD-450	3,730	7,290
AD-460	3,900	7,710
AD-560	8,490	14,850
AD-660	11,310	19,800

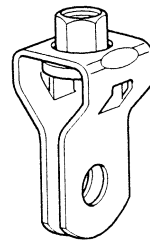

タンバックル(W)

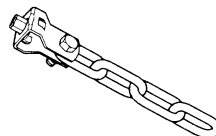

三連タンバックル(W)



白全ネジ(ユニクロメッキ)

その  
 関連  
 製品  
 他

## 樹脂サドル

適応管		SGP鉄管用(白)			適応管		被覆銅管ブリゾール用(白)																																																	
寸法	サドル		台 座		寸法	サドル		台 座																																																
10	G-2	90	1～5	60	$\frac{3}{8}$	P-3	90	1～5	60																																															
15	G-4	90	1～5	60	$\frac{1}{2}$	P-5	100	1～5	60																																															
20	G-6	90	6～7	60	$\frac{3}{4}$	P-8	110	8～9	80																																															
25	G-9	90	8～9	80	1	P-10	210	10～11	90																																															
32	G-11	150	10～11	90	適応管 被覆銅管ヴィック用(パールホワイト)																																																			
40	G-12	160	12～13	90	寸法	サドル		台 座																																																
50	G-14	170	14	110	$P\frac{3}{8}$	B-2	90	1～5	60																																															
適応管 被覆銅管用(アイボリー)					$P\frac{1}{2}$	B-3	90	1～5	60																																															
寸法	サドル		台 座		$P\frac{3}{4}$	B-7	100	6～7	60																																															
15	PC-6	100	6～7	60	$L\frac{1}{2}$	B-5		1～5																																																
20	PC-8	100	8～9	80	$L\frac{3}{4}$	B-8		8～9																																																
25	PC-10	190	10～11	90	適応管 被覆銅管サーモイン用(白)																																																			
32	PC-12	210	12～13	90	寸法	サドル		台 座																																																
適応管 CUP銅管用(ナチュラル)					$S\frac{1}{2}$	G-6		6～7																																																
寸法	サドル		台 座		$S\frac{3}{4}$	P-10		10～11																																																
$\frac{1}{2}$	T-1	90	1～5	60	$SE\frac{1}{2}$	G-4	90	1～5	60																																															
$\frac{5}{8}$	T-3	90	1～5	60	$SE\frac{3}{4}$	S-7	100	6～7	60																																															
$\frac{3}{4}$	T-5	90	1～5	60	<table border="1"> <thead> <tr> <th>品名</th> <th colspan="5">白全ネジニップル</th> </tr> <tr> <th>寸法</th> <th><math>\frac{1}{2}</math></th> <th>2</th> <th><math>2\frac{1}{2}</math></th> <th>3</th> <th>4</th> </tr> </thead> <tbody> <tr> <td>100L</td> <td>2,710</td> <td>3,140</td> <td>4,010</td> <td>4,230</td> <td>5,360</td> </tr> <tr> <td>200L</td> <td>5,200</td> <td>5,800</td> <td>7,130</td> <td>7,990</td> <td>10,240</td> </tr> <tr> <td>300L</td> <td>8,410</td> <td>9,440</td> <td>11,200</td> <td>12,380</td> <td>16,090</td> </tr> </tbody> </table>					品名	白全ネジニップル					寸法	$\frac{1}{2}$	2	$2\frac{1}{2}$	3	4	100L	2,710	3,140	4,010	4,230	5,360	200L	5,200	5,800	7,130	7,990	10,240	300L	8,410	9,440	11,200	12,380	16,090																	
品名	白全ネジニップル																																																							
寸法	$\frac{1}{2}$	2	$2\frac{1}{2}$	3						4																																														
100L	2,710	3,140	4,010	4,230						5,360																																														
200L	5,200	5,800	7,130	7,990						10,240																																														
300L	8,410	9,440	11,200	12,380	16,090																																																			
1	T-7	100	6～7	60																																																				
$1\frac{1}{4}$	T-9	100	8～9	80																																																				
$1\frac{1}{2}$	T-11	190	10～11	90																																																				
2	T-13	220	12～13	90																																																				
適応管 VPビニール管用(グレー)					<table border="1"> <thead> <tr> <th rowspan="2">寸法 \ 品名</th> <th>真鍮</th> <th>エポ</th> <th>鉄</th> </tr> <tr> <th>持出ソケット</th> <th>持出ソケット</th> <th>持出ソケット</th> </tr> </thead> <tbody> <tr> <td><math>\frac{1}{2} \times 0.5</math></td> <td>430</td> <td></td> <td></td> </tr> <tr> <td><math>\frac{1}{2} \times 1.0</math></td> <td>430</td> <td>廃盤</td> <td>廃盤</td> </tr> <tr> <td><math>\frac{1}{2} \times 1.5</math></td> <td>590</td> <td>廃盤</td> <td>廃盤</td> </tr> <tr> <td><math>\frac{1}{2} \times 2.0</math></td> <td>710</td> <td>廃盤</td> <td>廃盤</td> </tr> <tr> <td><math>\frac{3}{4} \times 1.0</math></td> <td>1,270</td> <td></td> <td>廃盤</td> </tr> <tr> <td><math>\frac{3}{4} \times 1.5</math></td> <td>1,680</td> <td></td> <td>廃盤</td> </tr> <tr> <td><math>\frac{3}{4} \times 2.0</math></td> <td>2,000</td> <td></td> <td>廃盤</td> </tr> <tr> <td><math>1 \times 1.0</math></td> <td>1,820</td> <td></td> <td>廃盤</td> </tr> <tr> <td><math>1 \times 1.5</math></td> <td>2,180</td> <td></td> <td>廃盤</td> </tr> <tr> <td><math>1 \times 2.0</math></td> <td>2,700</td> <td></td> <td>廃盤</td> </tr> </tbody> </table>					寸法 \ 品名	真鍮	エポ	鉄	持出ソケット	持出ソケット	持出ソケット	$\frac{1}{2} \times 0.5$	430			$\frac{1}{2} \times 1.0$	430	廃盤	廃盤	$\frac{1}{2} \times 1.5$	590	廃盤	廃盤	$\frac{1}{2} \times 2.0$	710	廃盤	廃盤	$\frac{3}{4} \times 1.0$	1,270		廃盤	$\frac{3}{4} \times 1.5$	1,680		廃盤	$\frac{3}{4} \times 2.0$	2,000		廃盤	$1 \times 1.0$	1,820		廃盤	$1 \times 1.5$	2,180		廃盤	$1 \times 2.0$	2,700		廃盤
寸法 \ 品名	真鍮	エポ	鉄																																																					
	持出ソケット	持出ソケット	持出ソケット																																																					
$\frac{1}{2} \times 0.5$	430																																																							
$\frac{1}{2} \times 1.0$	430	廃盤	廃盤																																																					
$\frac{1}{2} \times 1.5$	590	廃盤	廃盤																																																					
$\frac{1}{2} \times 2.0$	710	廃盤	廃盤																																																					
$\frac{3}{4} \times 1.0$	1,270		廃盤																																																					
$\frac{3}{4} \times 1.5$	1,680		廃盤																																																					
$\frac{3}{4} \times 2.0$	2,000		廃盤																																																					
$1 \times 1.0$	1,820		廃盤																																																					
$1 \times 1.5$	2,180		廃盤																																																					
$1 \times 2.0$	2,700		廃盤																																																					
寸法	サドル		台 座																																																					
13	V-2	90	1～5	60																																																				
16	V-4	90	1～5	60																																																				
20	V-6	100	6～7	60																																																				
25	V-8	100	8～9	80																																																				
32	V-10	190	10～11	90																																																				
40	V-12	210	12～13	90																																																				
50	V-14	220	14	110																																																				
防振PPサドル																																																								
適応管 SGP鉄管用																																																								
寸法	サドル		台 座																																																					
20	320		1号	70																																																				
25	480		2号	80																																																				

(単位:円/個)



樹脂サドル

890・804★	<b>振れ止め金具・その他</b>
改定2008.8	【新定価 2008年8月～】

<b>890★</b>		
改定2008.8		
品名	寸法	単価
フレ止めセット	B型	420
	C型	350
	G型	150
	PH型	420
	PG型	420
	PG22型	510
	丸U字型	180
	角U字型	180
フレ止め用 ファイリング	1250L 2000L	450 見積り
フレ止め用 角バー	1200L 2000L	320 780

<b>804★</b>					
改定2008.8					
レジャーサーレス(メッキ両絞り巻き出し管)					
寸法	単価	寸法	単価	寸法	単価
LW-5	3,670				
LW-6					
LW-7					
LW-8					

品名 寸法	ヤトイ管 (白)	テストプラグ (アルミ)	テストプラグ (樹脂)
$3/8$			
$1/2$	290	310	140
$3/4$	380	490	230
1	650		490

<b>804★</b>												
改定2008.8												
品名	寸法	20	25	32	40	50	65	75	100	125	150	フリー
Aパット		460	460	460	710	710	710	900	900	1,300	1,300	1,510
ボイドシューズ						廃盤		廃盤	廃盤	廃盤	廃盤	

品名	寸法	単価
パイラック本体	1S	$3/8$ 150
	1	$3/8$ 170
	1W	$3/8$ 300
HB吊金具	1FD	$3/8$ 640
	44FD	$3/8$ 660
	38FD	$3/8$ 630
	30ID	$3/8$ 350

品名 寸法	ソケットブッシュ (鉄製)	ソケットブッシュ (エポ)	ソケットブッシュ (真鍮)
$3/4 \times 1/2 \times 30$	380	640	廃盤
$3/4 \times 1/2 \times 35$	430	710	980
$3/4 \times 1/2 \times 40$		830	
$3/4 \times 1/2 \times 50$	540	880	1,350
$3/4 \times 1/2 \times 65$	660	960	
$3/4 \times 1/2 \times 75$	790	1,050	1,950
$3/4 \times 1/2 \times 100$	1,170	1,300	2,810

品名	寸法	単価
エイムS型 (HCクランプ)	$3/8$	300
エイム30 (NHB-1)	$3/8$	550
エイム40 (NHB-1)	$1/2$	690
吊ハンガー	$3/8$	570
	$1/2$	780
ライトゲージ(Cフック)	$3/8$	220
NSダクター	$3/8$	8,360
吊輪ボルト		200

(単位:円/個)

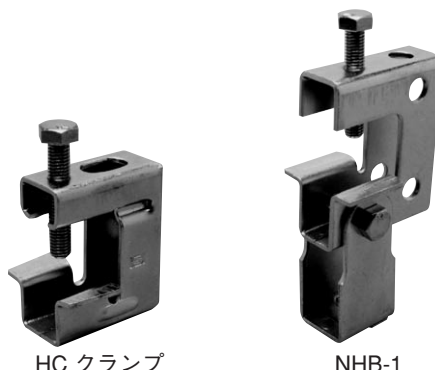

HC クランプ

NHB-1

その  
他の  
関連  
製品

<b>888★</b>	<b>インサート類</b>
改定2008.8	【新定価 2008年8月～】

インサート							
カラーホール		カラーストロング		スパイカー		スライダート	
CH-3040	130	CS-3040	130	S-3040	110	GSD-3050	140
CH-3050	160	CS-3050	140	S-4045	210	GSD-4050	420
CH-4060	270	CS-3080	190	プレートハンガー		GSD-3025	120
CH-5075	530	CS-4055	250	PH-3030	110	GSD-4025	530
ツインカット		CS-4080	290	デッキマン		スプリングハンガー	
TC-3030	100	CS-5080	640	DM-3040	120	SH-3040	140
カラースライダート		CS-5100	820	DM-4050	290	SH-4055	360
CSD-3025	110	CS-6150	1,330	アポロ		SHD-3025	180
CSD-4025	360			A-3030	70	SHD-4025	440

<b>889★</b>	<b>アンカー類</b>
改定2008.8	【新定価 2008年8月～】

アンカー							
オールアンカー-Cタイプ		ボルトアンカー-Bタイプ		グリップアンカー-GAタイプ		グリップアンカー-GTタイプ	
C-645	100	BA-1070	130	GA-30	60	GT-3030	70
C-850	120	BA-1080	140	GA-40	180	ALCアンカー-AXタイプ	
C-1060	200	BA-1210	230	GA-30S	70	AX-M10 (30ヶ入)	8,400
C-1270	290	BA-1212	310	GA-40S	140	AX-W30 (30ヶ入)	8,400
C-1610	520	BA-1610	440	MGA-30R	70	AX-1085 (30ヶ入)	8,100
C-3060	200	BA-3080	270	グリップアンカー-CTタイプ		ALCアンカー	
C-4070	280	BA-3100	170	CT-3040	70	TR-3865	280
C-4090	390	BA-4100	270	CT-4050	150	DX-38	270

ボードファスナー		NピンT・Yタイプ	
B-405	100	T-420	60
B-409	110	T-425	60
B-514	180	T-530	90
B-409S	120	T-630	100
B-416	120	T-640	100
B-423	130	Y-425	60
B-438	140	Y-530	80
		Y-640	100

オールプラグPBタイプ		
PB- 6×25	(100ヶ入)	1,080
PB- 8×25	(100ヶ入)	1,160
PB- 8×32	(100ヶ入)	1,280
PB-10×32	(100ヶ入)	1,800
PB-10×38	(100ヶ入)	2,200
PB-12×38	(100ヶ入)	2,330
PB-14×38	(100ヶ入)	3,000
PB-14×45	(50ヶ入)	1,830
PB-16×50	(50ヶ入)	3,170
PB-18×51	(50ヶ入)	3,170

(単位：円/個)

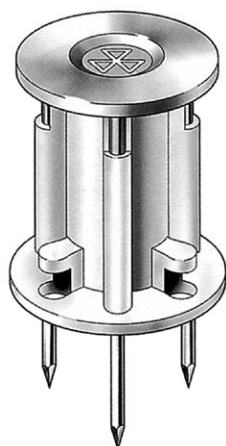

スパイカー

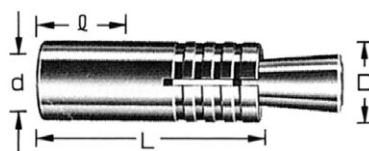

グリップアンカー GAタイプ

品名	サイズ 品番	A10660	A11680	A12214	A12225	A10663	A11681
		ドブメッキ付		ユニクロメッキ付		ステンレス製	
		片面穴	両面穴	片面穴	両面穴	片面穴	両面穴
ハヤウマ	900	3,870	4,220	3,800	4,000	12,050	12,050
	1.800	5,200	6,070	4,990	5,200	18,980	18,980
	2.520	8,400	8,800	7,490	7,490	27,380	27,380
	NO.1	1,190	—	1,180	—	4,380	—
	NO.2	1,270	—	1,270	—	4,820	—
	NO.3 (L)	1,270	—	1,270	—	4,020	—
	NO.3 (R)	1,270	—	1,270	—	4,020	—
	NO.4	2,920	—	2,920	—	8,030	—
	NO.5	3,930	—	3,930	—	11,320	—
NO.6	1,290	—	1,290	—	4,750	—	
NO.7	1,410	—	1,060	—	3,290	—	

品名	サイズ 品番	A10661	A12192	A12215	A12228	A10664	A12207
		ドブメッキ付		ユニクロメッキ付		ステンレス製	
		片面穴	両面穴	片面穴	両面穴	片面穴	両面穴
Lタイプ ハヤウマ	L-3443	2,190	2,420	2,140	2,560	12,000	12,000
	L-3464	2,400	2,920	2,580	3,120	12,480	12,480
	L-3404	3,650	4,320	3,380	4,620	13,000	12,960
	L-3406	4,380	5,340	4,060	5,680	14,350	14,300
	L-3408	5,390	6,630	4,920	7,050	16,080	16,030
	L-3410	7,190	8,710	6,670	9,240	23,020	22,940

品名	サイズ 品番	A10662	A12195	A12216	A12231	A10665	A12210
		ドブメッキ付		ユニクロメッキ付		ステンレス製	
		片面穴	両面穴	片面穴	両面穴	片面穴	両面穴
Mタイプ ハヤウマ	M-3434	5,450	5,450	5,220	6,220	17,330	20,590
	M-3445	6,070	6,070	5,780	6,760	17,720	21,050
	M-3456	7,580	7,580	7,240	8,420	24,560	29,170
	M-3467	8,420	8,420	8,030	9,280	26,480	31,460

品名	サイズ 品番	A10666	A12171	A型ブラケット	A10657	A10655	A10656
		ドブメッキ付	ステンレス製		ドブメッキ付	ユニクロメッキ付	ステンレス製
スペースマン	S-2075	3,090	13,250	15号	2,360	1,340	9,130
	S-2010	3,820	16,460	20号	4,940	2,820	13,510
	S-2012	5,620	23,890	25号	6,400	3,650	18,260
	S-2015	6,460	29,520	30号	7,410	4,220	23,360
	S-2575	3,930	16,460	40号	10,110	5,760	56,950
	S-2510	4,720	19,880				
	S-2512	6,740	28,910				
	S-2515	7,860	33,460				

(単位:円/個)



L型ブラケット				
タイプ	鉄ユニクロ	単価	ステンレス	単価
L 40 タ イ プ	NB-1	1,870	NB-1-SUS	7,260
	NB-2	2,160	NB-2-SUS	7,700
	NB-3	2,740	NB-3-SUS	9,020
	NB-4	3,560	NB-4-SUS	10,780
	NB-5	4,060	NB-5-SUS	12,980
	NB-6	4,620	NB-6-SUS	14,300
	NB-7	5,370	NB-7-SUS	15,180
	NB-8	6,180	NB-8-SUS	16,720
	NB-9	6,860	NB-9-SUS	18,480
L 50 タ イ プ	NB-21	4,320	NB-21-SUS	8,800
	NB-22	4,800	NB-22-SUS	10,780
	NB-32	5,640	NB-32-SUS	12,980
	NB-43	6,480	NB-43-SUS	16,390
	NB-53	7,680	NB-53-SUS	17,820
	NB-64	10,080	NB-74-SUS	21,120
	NB-74	11,520	NB-64-SUS	22,770

メッキフリーアングル		
LW-40	2.1	6,720
LW-50	2.1	10,560
LW-40P	1.8	8,160
LS-40	2.4	
LW-40P	2.5	8,160
LW-40	2.4	7,680
LS-40	1.8	
LS-40	2.1	6,720
LS-40	2.4	7,680
LW-50	2.4	13,440
LS-50	2.4	
LS-50	2.1	10,560

ステンレスフリーアングル		
SLW-50	2.1	33,750
SLS-50	2.1	33,750
SLW-40P	1.8	14,080
SLW-40	2.4	20,020
SLS-40	2.4	20,020

チャンネル君	
NC-100	1,680
NC-100S	1,440
NC-150	2,300
NC-150S	2,020
NC-200	2,780
NC-200S	
NC-300	4,180
NC-300L	5,180

門型ブラケット			
型番	単価	型番	単価
ドブメッキ NM-253	9,360	NM-253-SUS	25,300
ドブメッキ NM-255	12,240	NM-255-SUS	32,450
ドブメッキ NM-258	12,480	NM-258-SUS	43,450
ドブメッキ NM-353	10,800	NM-353-SUS	26,950
ドブメッキ NM-355	14,160	NM-355-SUS	34,650
ドブメッキ NM-358	19,920	NM-358-SUS	45,650
ドブメッキ NM-503	12,720	NM-503-SUS	29,700
ドブメッキ NM-505	16,560	NM-505-SUS	37,400
ドブメッキ NM-508	21,600	NM-508-SUS	47,300
ドブメッキ KM-200	4,320	〈取付足〉	
ドブメッキ KM-250	4,940	NL-1	630
ドブメッキ KM-300	5,760	NT-2	1,270
ドブメッキ KM-350	6,720		

品名 寸法	ハンディブラケット(プレス製)			アングル ブラケット赤錆
	メッキ	ドブメッキ	ステンレス	
150等辺	1,620	2,420	6,600	
200等辺	3,340	5,070	9,770	
250等辺	4,320	6,340	13,200	
300等辺	5,070	7,600	16,900	
400等辺	6,910	10,370	41,180	

(単位：円)

アングル君 ジョイント金具(ドブメッキ)			
ジョイント金具	単価	ジョイント金具	単価
取付足 NT-40R	1,490	ストッパー左 No.3	1,250
取付足 NT-40L	1,490	ストッパー右 No.3	1,250
取付足 NL-1	910	三方通し No.4	2,780
取付足 NT-2	1,490	四方通し No.5	3,790
コーナーNo.1	1,100	台座 No.6	1,060
通しコーナーNo.2	1,150		

(単位：円)



ハンディブラケット



L型ブラケット