

807・808★

## ウレタンAG・MS・TG・UP/EP



株式会社 アカネ

改定2022.2

【新定価 2022年2月～】



日栄インテック株式会社

807★

807★

807★

808★

改定2022.2

改定2022.2

改定2022.2

改定2022.2

## ウレタンAG

## ウレタンMS

## ウレタンTG

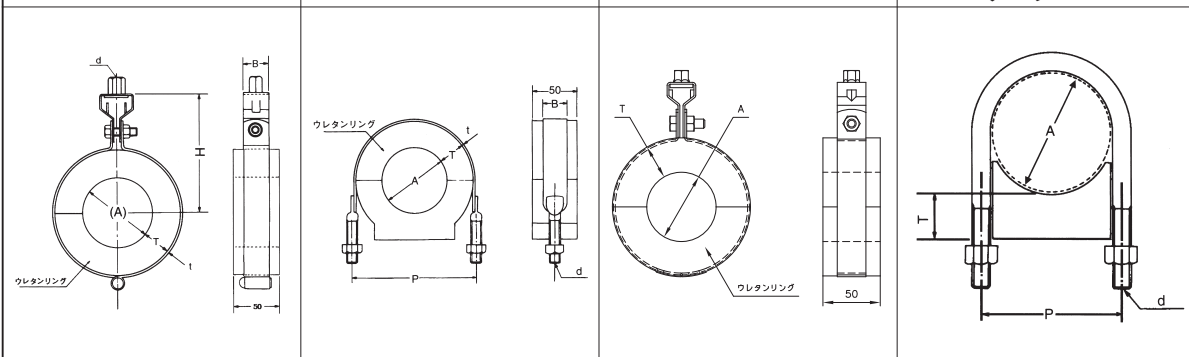
ウレタンUP  
ウレタンEP

保温厚	20 mm				25 mm				30 mm				40 mm				50 mm					
	呼び径	AG	MS	TG	UP EP	AG	MS	TG	UP EP	AG	MS	TG	UP EP	AG	MS	TG	UP EP	AG	MS	TG	UP EP	
15A 1/2	1,520	1,340	1,780	890	1,670	1,440	1,830	910	1,850	1,610	1,950	960			2,510							
20A 3/4	1,520	1,450	1,890	990	1,930	1,620	2,050	1,020	2,180	1,690	2,240	1,090	2,570	2,090	2,600	1,250						
25A 1	1,620	1,510	1,980	1,110	1,950	1,690	2,110	1,130	2,280	1,780	2,350	1,220	2,660	2,210	2,780	1,400						
32A 1 1/4	1,730	1,600	2,020	1,180	1,980	1,740	2,130	1,220	2,410	1,940	2,550	1,270	2,860	2,430	2,980	1,500						
40A 1 1/2	1,880	1,710	2,200	1,270	2,390	1,920	2,390	1,330	2,660	2,120	2,710	1,380	3,070	2,640	3,440	1,590						
50A 2	1,990	1,990	2,620	1,360	2,530	2,080	2,800	1,420	2,840	2,300	3,100	1,510	3,530	2,860	3,950	1,880						
65A 2 1/2	2,680	2,170	3,060	1,620	2,740	2,400	3,200	1,820	3,080	2,610	3,710	1,940	3,810	3,230	4,150	2,100						
80A 3	2,890	2,550	3,440	1,840	2,950	2,660	3,500	2,020	3,320	2,870	3,940	2,150	4,080	3,540	4,710	2,290	5,110	4,250	5,140	2,900		
100A 4					3,360	2,840	3,640	2,250	4,180	3,180	4,150	2,350	4,580	3,960	6,390	2,480	5,300	4,800	5,290	3,070		
125A 5					4,790	4,590	5,360	3,010	5,430	4,950	5,750	2,760	6,040	5,570	6,890	3,590	7,360	6,770	7,820	3,750		
150A 6					5,110	4,860	5,890	3,150	5,680	5,150	6,180	3,150	6,290	5,880	13,710	3,380	8,340	7,540	8,960	4,180		
200A 8									10,790	8,070	13,180	3,390	11,750	8,610	22,110	4,610	12,320	9,840	15,450	5,220		
250A 10									19,320	10,840	21,300	10,790	20,450	11,320		7,000	21,950	11,380	23,480	7,840		
300A 12													26,590	16,500		8,480	33,250	17,050		8,820		

(単位: 円 / 個)

\* 製品の呼び方 [タイプ] - [呼び径(A)] - [厚さ(T)] - [長さ(L)] L = 50mm

(例) MS-15-20-50

\* MSタイプ・AGタイプ・TGタイプは、ウレタン+付属金額の価格です。

\* UP / EPタイプは、ウレタン+Uボルトの価格です。